

**TUBE FRAME:**

FINISHED OPENING WIDTH:

FINISHED OPENING HEIGHT:

TUBE SIZE:

2" X 4"    2" X 6"    2" X 8"

**MATERIAL (CHOOSE ONE):**

MILL FINISH STAINLESS STEEL:

POWDER COATED MILD STEEL:

BLACK:

GRAY:

WHITE:

CUSTOM:

QUANTITY:

ORDER:    QUOTE:    #

CUSTOMER:

JOB:

DATE:

SIGNATURE:

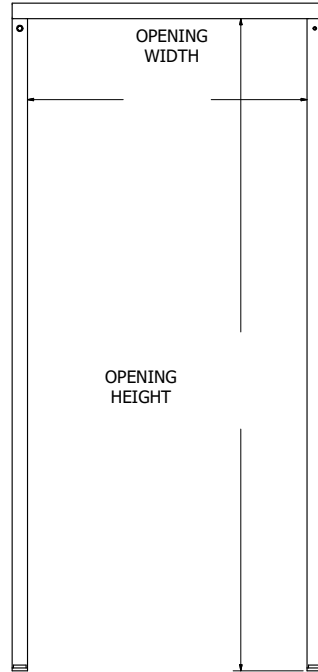

4", 6" OR 8"

0.19" WALL THICKNESS  
7/16" HOLE THIS SIDE. 1" HOLE OPPOSITE SIDE

ALL FASTENERS PROVIDED BY PHOENIX DOOR SYSTEMS

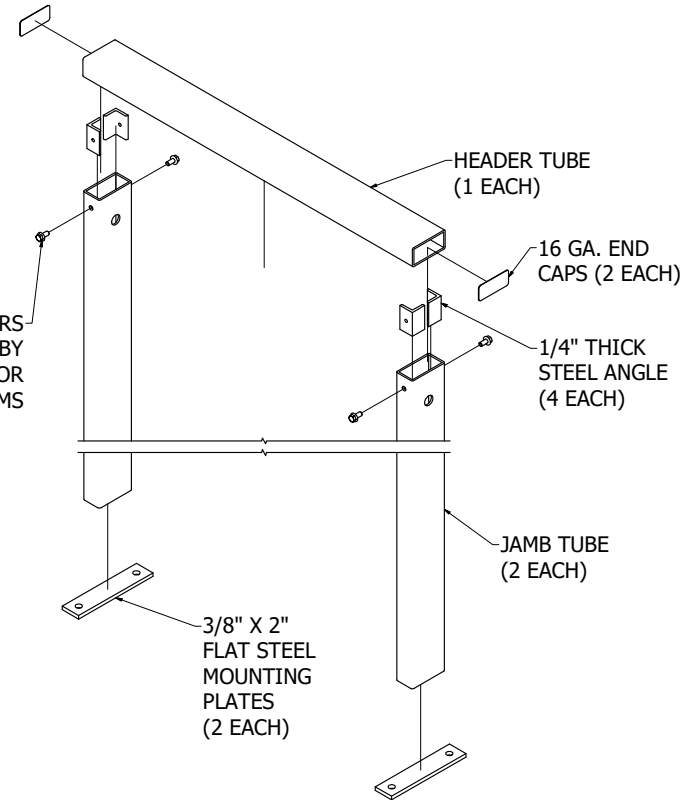

**ROUGH OPENING = FOW + 4 1/4" X FOH + 2 3/16"**

**NOTES:**

ALL DIMS IN INCHES

The information and/or material in this document is the Property of Phoenix Door Systems. This information may not be used, reproduced, published or disclosed to others without permission from Phoenix Door Systems. It is to be used only for manufacturing items specified within the document.

SAE TOLERANCE		METRIC	
.x = ±.1	.xx = ±.01	.x = ±.3	.xx = ±.13
.xxx = ±.005		.xxx = ±.013	
REMOVE ALL BURRS			
BREAK ALL SHARP EDGES			

Title: TUBE FRAME	
Dwg No:	
Drawn: B. CLARK	Date: 11/14/19
Rev.	

